

CAPRICORN MUNICIPAL DEVELOPMENT GUIDELINES

CONTROL OF TRAFFIC

C201

CONSTRUCTION SPECIFICATION

TABLE OF CONTENTS

CLAUSE	CONTENTS	PAGE
GENERAL		3
C201.01	SCOPE	3
C201.02	REFERENCE DOCUMENTS	3
C201.03	TRAFFIC GUIDANCE SCHEME	4
C201.04	SIDE ROADS AND PROPERTY ACCESSES	5
C201.05	TRAFFIC CONTROLLERS	5
C201.06	APPROVED CLOTHING FOR WORK PERSONNEL	5
C201.07	TEMPORARY SPEED ZONING	5
C201.08	PLANT AND EQUIPMENT	5
TEMPORARY ROADWAYS AND DETOURS		6
C201.09	DESIGN STANDARDS	6
C201.10	DESIGN DRAWINGS	6
C201.11	DRAINAGE	6
C201.12	CONSTRUCTION OF EARTHWORKS AND PAVEMENT	7
C201.13	SURFACING	7
C201.14	GUARDFENCE	7
C201.15	C201.15 OPENING TO TRAFFIC	7
C201.16	MAINTENANCE	8
C201.17	REMOVAL	8
ARRANGEMENTS FOR TRAFFIC		8
C201.18	CONSTRUCTION UNDER TRAFFIC	8
C201.19	OPENING COMPLETED WORK	9
TRAFFIC CONTROL DEVICES		9
C201.20	ARRANGEMENT OF TRAFFIC CONTROL DEVICES	9

C201.21	MAINTENANCE OF TRAFFIC CONTROL DEVICES	9
C201.22	ADEQUATE TRAFFIC CONTROL DEVICES.....	9
C201.23	REGULATORY TRAFFIC CONTROL SIGNS AND DEVICES.....	9
C201.24	SIGNS	10
C201.25	SUPPLEMENTARY SIGNS	10
C201.26	FLASHING ARROW SIGNS	10
C201.27	BARRIER BOARDS	10
C201.28	HIGH VISIBILITY MESH FENCING.....	10
C201.29	TEMPORARY POST-MOUNTED DELINEATORS	11
C201.30	CONES AND BOLLARDS.....	11
C201.31	TRAFFIC WARNING LAMPS	11
C201.32	TEMPORARY PAVEMENT MARKINGS	11
C201.33	TEMPORARY LINEMARKING	11
C201.34	RAISED PAVEMENT MARKERS	12
ANNEXURE C201A		13
C201.35	SUPPLEMENTARY TEMPORARY WARNING SIGNS TO MUTCD	13

Keeping the Capricorn Municipal Development Guidelines up-to-date

The Capricorn Municipal Development Guidelines are living documents which reflect progress of municipal works in the Capricorn Region. To maintain a high level of currency that reflects the current municipal environment, all guidelines are periodically reviewed with new editions published and the possibility of some editions to be removed. Between the publishing of these editions, amendments may be issued. It is important that readers assure themselves they are using current guideline, which should include any amendments which may have been published since the guideline was printed. A guideline will be deemed current at the date of development approval for construction works.

GENERAL

C201.01 SCOPE

C201.01.01 The work to be executed under this Specification consists of all work necessary to provide for the safe movement of traffic and the protection of persons and property through and/or around the work site.

C201.01.02 The extent of work includes the design, construction, maintenance and removal of temporary roadways and detours, the provision of traffic controllers, signposting, roadmarkings, raised pavement markers, lights, barriers and any other items required. All temporary traffic arrangements required by works are included under this Specification except where specified otherwise.

***Works
Included***

C201.01.03 Control of traffic shall be in accordance with the Queensland Department of Transport and Main Roads (DTMR) Manual of Uniform Traffic Control Devices (MUTCD), this Specification, and the Drawings.

Standards

C201.01.04 Wherever the word 'should' occurs in the MUTCD the word 'shall' applies and the required action is the Contractor's responsibility.

***Contractor's
Responsibility***

C201.01.05 The following order of priority for interpretation of documents will apply: (Please note that reference to a Guideline or Standard, is reference to the latest version of the relevant document, unless specifically a version number is specifically stated):

- (a) CMDG C201 Control of Traffic – Construction Specification
- (b) Queensland Department of Main Roads Manual of Uniform Traffic Control Devices
- (c) AUSTROADS Publications
- (d) AS 1743 Road Signs Specifications
- (e) AS 1744 Standard Alphabets for Road Signs
- (f) AS 1906 Retro-reflective Materials & Devices for Road Traffic Control Purposes

***Order of
Priority***

C201.02 REFERENCE DOCUMENTS

C201.02.01 Documents referenced in this Specification are listed in full below whilst being cited in the text in the abbreviated form or code indicated.

***Documents
Standards
Test Methods***

(a) Australian Standards

- AS 1743 - Road Signs Specifications
- AS 1744 - Standard Alphabets for Road Signs
- AS 1906 - Retro-reflective Materials & Devices for Road Traffic Control Purposes
- AS 1742 - Manual of uniform traffic control devices
- AS 1742.3 - Traffic control for works on roads

- AS 1742.14 - Traffic signals
- AS/NZS 1906.1 - Retroreflective sheeting
- AS/NZS 3845 - Road safety barrier systems and devices
- AS/NZS 3845.1 - Road safety barrier systems
- AS 4191 - Portable traffic signal systems
- AS 4192 - Illuminated flashing arrow signs

(b) AUSTRROADS Publications

- AUSTRROADS - Guide to Traffic Management, Part 6: Intersections, Interchanges and Crossings
- AUSTRROADS - Guide to Road Design, Part 3: Geometric Design
- AUSTRROADS - Guide to Road Design, Part 4A: Signalised and Unsignalised Intersections

(c) Queensland Department of Main Roads Publications

- MUTCD - Manual of Uniform Traffic Control Devices.

C201.03 TRAFFIC GUIDANCE SCHEME

- | | | |
|------------|--|---|
| C201.03.01 | All works shall be constructed with the least possible obstruction to traffic. | <i>Minimise
Obstruction</i> |
| C201.03.02 | The Contractor shall obtain all necessary approvals from Local Governments and other Authorities for temporary traffic arrangements except where specified otherwise. | <i>Contractor's
Responsibility</i> |
| C201.03.03 | Prior to undertaking work which would involve any obstruction whatsoever to traffic, the Contractor shall submit, for Local Government's approval at the pre-start meeting, a Traffic Guidance Scheme in accordance with Part 3 of the MUTCD. | <i>Guidance
Scheme</i> |
| C201.03.04 | <p>The Traffic Guidance Scheme shall include:-</p> <ul style="list-style-type: none"> (a) design drawings for any temporary roadways and detours in accordance with Clause C201.10 showing pavement, wearing surface and drainage details, (b) details of arrangements for construction under traffic in accordance with Part 3 of MUTCD, and (c) a signpost layout plan showing: <ul style="list-style-type: none"> (i) location, size and legend of all temporary signs (ii) temporary regulatory signs and temporary speed zones, and (iii) all traffic control devices such as temporary traffic signals, linemarking, pavement reflectors, guideposts, guard fence and barrier boards. | <i>Control Plan
Contents</i> |
| C201.03.05 | Where the Traffic Guidance Scheme involves Regulatory Traffic Control Signs or Devices and/or where the disruption to local traffic is significant, the prior approval of the Local Government, or in the case of an intersection with a gazetted or State controlled road, the DTMR District Director for the area, will be sought and obtained. Any approval may include public advertising requirements. | <i>Notice</i> |
| C201.03.06 | The Traffic Guidance Scheme shall be in accordance with the requirements of this specification and the Drawings. | |

C201.03.07	Special consideration to the safety of pedestrians and workers shall be given in the preparation of the traffic guidance scheme. Particular care shall be taken when requiring reversal of traffic flows or the separation of unidirectional flow by medians or other physical separation.	<i>Safety</i>
C201.04	SIDE ROADS AND PROPERTY ACCESSES	
C201.04.01	At all times, safe and convenient passage shall be provided for vehicles, pedestrians and stock to and from side roads and property accesses connecting to the roadway. Advise the property owners with a letter drop at least 24 hours before any interruption.	<i>Access</i>
C201.05	TRAFFIC CONTROLLERS	
C201.05.01	All traffic controllers shall be appropriately trained in the duties of traffic controllers in accordance with the MUTCD.	<i>Trained Traffic Controllers</i>
C201.06	APPROVED CLOTHING FOR WORK PERSONNEL	
C201.06.01	All personnel working in close proximity to traffic shall wear high visibility clothing to the requirements of the MUTCD.	<i>Safety Clothing</i>
C201.07	TEMPORARY SPEED ZONING	
C201.07.01	Where a temporary speed limit has been approved by the Local Government or in the case of a gazetted or State controlled road the District Director of DMR for the area, the Contractor shall arrange for the supply of appropriate temporary speed zoning signs, including posts and fittings, for erection. Signs shall be covered when the speed zone is not in use and removed from the site when the speed zone is no longer required as part of the provision for traffic. A diary recording operation times of the speed zone shall be kept by the Contractor.	<i>Speed Zone Signs</i>
C201.08	PLANT AND EQUIPMENT	
C201.08.01	During the day where plant and equipment are working in a position adjacent to traffic the work area shall be clearly delineated in accordance with MUTCD.	<i>Delineation</i>
C201.08.02	At night, where traffic is permitted to use the whole or portion of the existing road, all plant items and similar obstructions shall be removed from the normal path of vehicles to provide a lateral clearance of at least 6 m where practicable, with a minimum clearance of 1.2 m.	<i>Night Time Clearance</i>

TEMPORARY ROADWAYS AND DETOURS

C201.09 DESIGN STANDARDS

- | | | |
|------------|--|--|
| C201.09.01 | The standard of alignment and grading adopted shall be in accordance with specific provisions of this Specification and shall otherwise be in accordance with the AUSTRROADS publication 'Guide Road Design - Part 3: Geometric Design'. | <i>Alignment & Grading</i> |
| C201.09.02 | Intersections shall be designed in accordance with the AUSTRROADS publication 'Guide to Traffic Management - Intersections, Interchanges and Crossings'. | <i>Intersections</i> |
| C201.09.03 | Design drawings, geometric standards, design speed, wearing surface type and pavement design of the proposed temporary roadways and detours shall be submitted by the Contractor with the Traffic Guidance Scheme. | <i>Standards & Pavement</i> |

C201.10 DESIGN DRAWINGS

- | | | |
|------------|---|------------------------|
| C201.10.01 | <p>Design drawings submitted for approval shall show:</p> <ul style="list-style-type: none"> (a) Alignment and grading at a horizontal scale of 1:2000 for rural roads and 1:500 for urban roads. Where the temporary road re-joins the existing road, levels showing the full cross section shall be extended along the existing road for a minimum length of 200 m. (b) A sight distance diagram if opposing traffic is to use a single carriageway (c) Intersections, and any other locations where traffic may be required to make turning, merging or diverging movements, at a scale of 1:500. (d) Pavement marking details. (e) Sufficient cross-sections to indicate the feasibility of making connections between various parts of the work. (f) Sufficient dimensions, especially lane widths, to make clear the geometry and clearances of the proposed Works. (g) A north point or some other location method to orientate the plan. | <i>Contents</i> |
|------------|---|------------------------|

C201.11 DRAINAGE

- | | | |
|------------|---|------------------------|
| C201.11.01 | <p>Drainage structures and drains shall be constructed in accordance with the following Specifications:</p> <ul style="list-style-type: none"> C220 - Stormwater Drainage - General C221 - Pipe Drainage C223 - Drainage Structures C224 - Open Drains, including Kerb and Gutter | <i>Standard</i> |
|------------|---|------------------------|

C201.11.02	Drainage proposed in accordance with Clause C201.03 shall be able to cope with upstream rainfall run-off resulting from all rainfall intensities up to that expected for a once in five year frequency, without overflow over the road.	<i>Design Frequency</i>
C201.11.03	Pavements shall be designed and constructed to not pond water on the wearing surface or shoulders. Temporary formations to be constructed shall not dam water.	<i>Pavement Drainage</i>
C201.12 CONSTRUCTION OF EARTHWORKS AND PAVEMENT		
C201.12.01	Temporary roadways shall be constructed in accordance with the following Specifications: C211 - Control of Erosion and Sedimentation C212 - Clearing And Grubbing C213 - Earthworks C242 - Flexible Pavements	<i>Temporary Roadways</i>
C201.13 SURFACING		
C201.13.01	The wearing surface width shall extend across the full width of the traffic lanes plus the width for each shoulder, or as shown on the Drawings.	<i>Wearing Surface</i>
C201.13.02	The wearing surface shall be carried onto any existing connecting roadway so as to finish square to the existing roadway centreline.	<i>Tie-in to existing work</i>
C201.13.03	Surfacing shall be constructed in accordance with: C244 - Sprayed Bituminous Surfacing; and/or C245 - Asphaltic Concrete	<i>Standards</i>
C201.14 SAFETY BARRIER		
C201.14.01	Temporary road safety barrier systems to AS/NZS 3845.1, shall be erected on all temporary embankments where the vertical height between the edge of the shoulder and the intersection of the embankment slope and natural surface exceeds 2m and as otherwise shown on the drawings.	<i>Warrant</i>
C201.14.02	Safety barrier shall be erected in accordance with: C264 - Guardfence	<i>Erection</i>
C201.15 OPENING TO TRAFFIC		
C201.15.01	Temporary roadways and detours (including portable or temporary traffic signals sites) shall not be open to traffic until they have been inspected, approved and authorised in writing by the relevant Authority.	<i>Approval to use</i>
C201.15.02	All signposting, pavement marking, safety barrier and portable or temporary traffic signals shall be completed before the opening of temporary roadways to traffic.	<i>Signposting</i>

- C201.15.03 Unless otherwise approved by the relevant Authority, the opening of temporary roadways shall be arranged so that sections of existing roadway being replaced are not disturbed for a minimum of forty-eight hours in the event of temporary roadway failure and there is a warrant to redirect traffic back onto the existing roadway. The determination to redirect traffic shall be by the relevant Authority. **Existing Roadway Retained**
- C201.16 MAINTENANCE**
- C201.16.01 The Contractor shall be responsible for the maintenance of temporary roadways and detours and shall ensure the road surface is kept safe for traffic. Any potholes or other failures shall be repaired without delay. **Contractor's Responsibility**
- C201.17 REMOVAL**
- C201.17.01 Upon completion of the Work the temporary roadways and/or detour arrangements shall be removed and the area restored to a condition equivalent to that which existed prior to the commencement of the work. **Restoration**

ARRANGEMENTS FOR TRAFFIC

C201.18 CONSTRUCTION UNDER TRAFFIC

- C201.18.01 Where a temporary roadway or a detour is not provided or available then, subject to the approval of the relevant Authority, construction under traffic may be permitted provided a minimum lane width will be as per Table C201.18.01, extracted from MUTCD Part 3 Section 4.13.3.

Table C201.18.01 Minimum Lane Widths

Posted Speed Limit During Roadworks (km/h)	Minimum Lane Width (m)
60 or less	3.0
70 – 90	3.2
Greater than 90	3.4

Lane Width

Note: Temporary lane widths are not to be greater than existing lane widths.

- C201.18.02 The carriageway/s shall be restored to a safe and trafficable state for through traffic prior to cessation of work each day in accordance with the approved Traffic Guidance Scheme. **Carriageway Restoration**
- C201.18.03 Full details of temporary signposting, traffic control devices and traffic control methods, in accordance with the appropriate arrangement diagrams in MUTCD, are to be submitted for the relevant Authority's approval at least five working days before undertaking any work which would involve construction under traffic. **Signs and Markings**

C201.19 OPENING COMPLETED WORK

- | | | |
|------------|---|---|
| C201.19.01 | The Contractor shall give at least five working days written notice confirming the date of opening completed work to traffic. The procedure for opening shall be determined through consultation between the Contractor and the relevant Authority. | <i>Written Notice</i> |
| C201.19.02 | The Contractor shall be responsible for the removal of all temporary traffic control devices no longer required for the safety of traffic, when the Works or part thereof are opened to traffic. | <i>Contractor's Responsibility</i> |

TRAFFIC CONTROL DEVICES**C201.20 ARRANGEMENT OF TRAFFIC CONTROL DEVICES**

- | | | |
|------------|--|------------------------------------|
| C201.20.01 | The arrangement and placement of traffic control devices shall be carried out in accordance with the approved Traffic Guidance Scheme, and the MUTCD. The arrangement diagrams illustrate the more common examples of the arrangement of traffic control devices and set out the minimum requirements. | <i>Arrangement Diagrams</i> |
| C201.20.02 | All temporary traffic control devices when no longer required shall be covered and/or removed without delay in order to maintain unambiguous safe guidance to traffic. | <i>Unnecessary Signs</i> |

C201.21 MAINTENANCE OF TRAFFIC CONTROL DEVICES

- | | | |
|------------|---|---|
| C201.21.01 | All traffic control devices shall be maintained in accordance with the MUTCD so that they are in good order and in the correct positions day and night. They shall be neat and clean, and signs shall be clear and legible at all times. | <i>Contractor's Responsibility</i> |
| C201.21.02 | The Contractor may need to be contacted outside normal working hours to arrange for adjustments or maintenance of traffic control devices. The Contractor shall notify the Superintendent, the Local Government and the local Police, in writing, the names, addresses, and means of communicating with personnel nominated for this purpose. | <i>Out of Hours Contact</i> |

C201.22 ADEQUATE TRAFFIC CONTROL DEVICES

- | | | |
|------------|---|-------------------------------------|
| C201.22.01 | Where the Contractor fails to provide and maintain adequate traffic control devices specified in this Specification, the Superintendent and/or Local Government may arrange to have such items provided and maintained. | <i>Default by Contractor</i> |
| C201.22.02 | The cost of providing and maintaining adequate traffic control devices arranged by the Superintendent and/or Local Government shall be borne by the Developer through the Construction maintenance bond. | <i>Contractor's Cost</i> |

C201.23 REGULATORY TRAFFIC CONTROL SIGNS AND DEVICES

C201.23.01 A Regulatory Traffic Control Sign or Device shall be in accordance with the MUTCD, and shall require approval by the Local Government, or in the case of a gazetted or State controlled road the District Director of DMR for the area, before its erection. ***Prior Approval***

C201.24 SIGNS

C201.24.01 Signs shall be designed and manufactured in accordance with AS 1743. Details of each letter shall be as shown in AS 1744. ***Specifications***

C201.24.02 The reflective material used on signs shall be Class 1 material complying with AS 1906.1 except where otherwise specified. ***Reflective Material***

C201.25 SUPPLEMENTARY SIGNS

C201.25.01 Signs supplementary to the MUTCD are shown in Annexure C201A. Approval must be obtained from DTMR prior to their use.

(a) Heavy Machinery Crossing

This temporary sign, shown as Sign SW5-22, if approved, may be used in lieu of W5-22, trucks entering.

(b) Cycle Hazard Grooved Road

This temporary sign, shown as Sign ST1-10, if approved, may be used in addition to T1-10 of AS 1742.3 where the road is grooved and is a hazard to cyclists.

(c) Tar Spraying Possible Short Delay

This temporary sign, shown as Sign ST3-1, if approved, may be used in addition to T3-1 for bituminous surfacing works.

C201.26 FLASHING ARROW SIGNS

C201.26.01 Flashing arrow signs shall comply with the MUTCD.

C201.27 BARRIER BOARDS

C201.27.01 Barrier boards shall comply with the MUTCD. ***Standard***

C201.27.02 Trestles supporting the barrier boards may be manufactured of timber, metal or other suitable material and shall be yellow. The trestles shall provide firm supports for the barrier board and be kept in place by sandbags or other devices. The bases of the trestles shall not protrude beyond the ends of the boards. ***Trestle Support***

C201.28 HIGH VISIBILITY MESH FENCING

C201.28.01 High visibility mesh fencing shall be constructed where shown on the Drawings or Traffic Guidance Scheme.

C201.28.02 High visibility mesh fencing shall be constructed in accordance with the MUTCD, containment fences.

C201.28.03 The mesh fencing shall be para-web or equivalent as approved by the Superintendent.

C201.29 TEMPORARY POST-MOUNTED DELINEATORS

C201.29.01 In addition to the requirements of MUTCD, temporary post mounted delineators shall be provided in conjunction with high visibility mesh fencing which is erected parallel to and in close proximity to traffic.

C201.30 CONES AND BOLLARDS

C201.30.01 Traffic cones and bollards shall comply with the MUTCD and be placed in accordance with the arrangement diagrams in the MUTCD.

Standard and Placement

C201.30.02 Unless cones are firmly fixed in position they shall be used only while work is in progress, or in locations where there is an employee in attendance who shall reinstate any of the cones which have been dislodged by traffic. Otherwise they shall be removed and bollards or barriers substituted.

Conditions of Use

C201.30.03 Cones and bollards used under night conditions shall be reflectorised in accordance with the MUTCD.

Reflectorised for Night Work

C201.31 TRAFFIC WARNING LAMPS

C201.31.01 Traffic warning lamps shall comply with the MUTCD. The Contractor shall ensure that warning lamps are in good working order, correctly aligned and positioned in accordance with the MUTCD, before the site is left unattended.

Standards and Positioning

C201.32 TEMPORARY PAVEMENT MARKINGS

C201.32.01 All pavement markings shall be reflectorised and consist of painted lines, roadmarking tape and/or raised pavement markers in accordance with the relevant Australian Standards or as otherwise approved by the Superintendent and shall be provided in accordance with the MUTCD.

Reflectorised Markings

C201.32.02 Where the adjoining roadway is edge lined, temporary roadways shall be similarly edge lined.

Adjoining Work

C201.33 TEMPORARY LINEMARKING

C201.33.01	Where temporary line marking is required on the final wearing surface, only pavement marking tape shall be used.	<i>On Final Surface</i>
C201.33.02	Where the pavement line marking has become ineffective in the opinion of the Superintendent and/or Local Government, remarking shall be undertaken within forty-eight hours of direction by the Superintendent.	<i>Contractor's Cost</i>
C201.33.03	Where a single carriageway is opened adjacent to or used in lieu of an existing dual carriageway length, pavement arrows indicating the direction of flow of traffic shall be placed at not more than 500 m intervals or at a spacing nominated by the Superintendent. The arrows shall be removed if the section is then reincorporated as dual carriageway.	<i>Pavement Arrows</i>
C201.33.04	Immediately before or after placement of new markings all superseded pavement markings shall be obliterated or removed.	<i>Old Markings Removed</i>
C201.33.05	On a final surface, obliteration by over painting shall not be permitted.	
C201.34 RAISED PAVEMENT MARKERS		
C201.34.01	Where raised pavement markers have become ineffective in the opinion of the Superintendent and/or Local Government, they shall be replaced within twenty four hours of direction by the Superintendent.	<i>Ineffective Markers</i>
C201.34.02	The cost of replacing ineffective pavement markers shall be borne by the Contractor.	<i>Contractor's Cost</i>
C201.34.03	All superseded raised pavement markers shall be immediately removed from the pavement by the Contractor.	<i>Removal of Superseded Markers</i>

ANNEXURE C201A

C201.35 SUPPLEMENTARY TEMPORARY WARNING SIGNS TO MUTCD

Black letters and border on yellow reflectorised ground
 Dimensions are in mm

(i) SW5-22

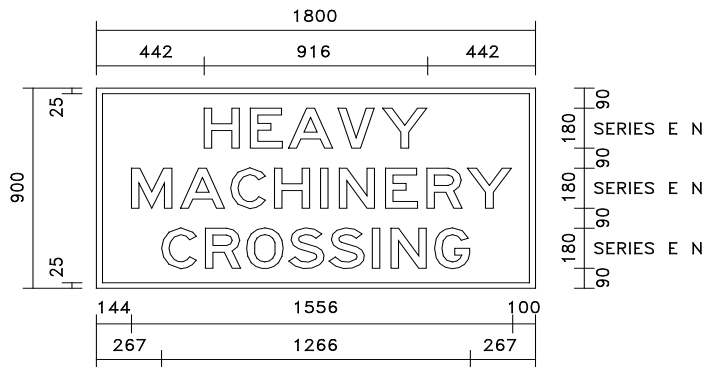

(ii) ST1-10

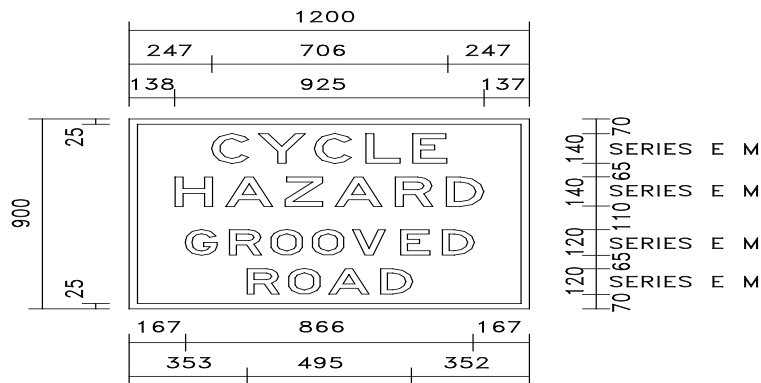

(iii) ST3-1

