

METER BOX DETAIL  
AT PROPERTY LINE

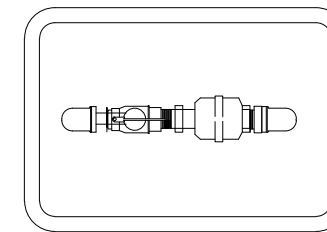
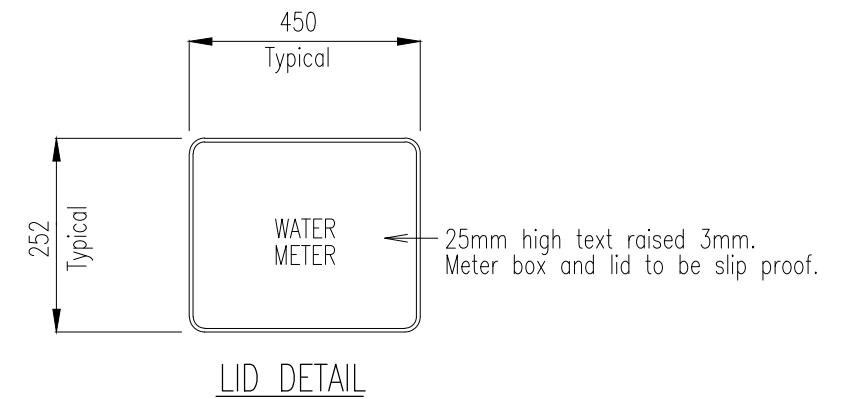

PLAN

NOTES:

1. Ball valves must be Water Mark Approved.
2. Ball valves shall be made from brass or gunmetal and shall have a chrome plated ball.
3. 20mm I.D. Ball Valves shall have BSP threaded male and female ends..
4. All Polyethylene Pipes and Fittings shall be CLASS PN 12.5 or PN16 in Accordance with AS/NZS 4130 and AS/NZS 4129 respectively.
5. 20mm Ball valves to be fixed in place 250mm below finished surface level.
6. Watermeters shall comply with A.S.3563.3 – 1998 which incorporates a dual check valve
7. \* Alignment for existing connections will vary according to the area. Replacement connections and meters will align with existing property line connection.
8. NO GALVANIZED FITTINGS TO BE USED.
9. All dimensions in millimetres
10. Meter box to be provided by Council

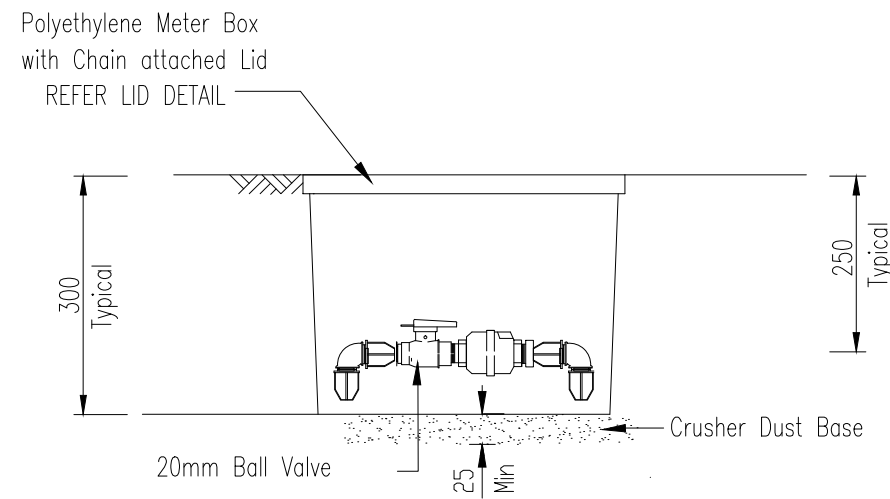

ELEVATION

METER BOX  
NTS

APPLICABILITY TABLE							
Council	BSC	CHRC	GRC	LSC	IRC	MRC	RRC
<b>Applicable</b>	Yes	No	Yes	Yes	Yes	No	Yes
<b>Poly Pipe and Class</b>	PN12.5		PN16	PN12.5	PN12.5		PN12.5
<b>Applicable DWG</b>	CMDG-W-093						

REVISIONS	DATE
G IRC ADDED	11/2016
F CHANGE + POLY CLASS FOR GRC	03/2015
E GRC AND LSC ADDED	09/2014
D RRC AMENDMENTS	09/2014
C APPLICABILITY CHANGES	01/2013
B RRC AMENDMENTS	05/2011
A ORIGINAL ISSUE	01/2010

**DISCLAIMER.**  
The authors and sponsoring organisations shall have no liability or responsibility to the user or any other person or entity with respect to any liability, loss or damage caused or alleged to be caused, directly or indirectly, by the adoption and use of these Standard Drawings including, but not limited to, any interruption of service, loss of business or anticipatory profits, of consequential damages resulting from the use of these Standard Drawings. Persons must not rely on these Standard Drawings as the equivalent of, or a substitute for, project-specific design and assessment by an appropriately qualified professional.

**Capricorn Municipal Development Guidelines**

Incorporating:  
Banana Shire Council (BSC) Livingstone Shire Council (LSC)  
Central Highlands Regional Council (CHRC) Maranoa Regional Council (MRC)  
Gladstone Regional Council (GRC) Rockhampton Regional Council (RRC)  
Isaac Regional Council (IRC)

**20 & 25MM WATER METER DETAILS  
BELOW GROUND**

ROADS						
STANDARD DRAWING						
CMDG-W-091						
REV.	A	B	C	D	E	F
REV.	G					