

PLAN
SLAB MOUNTED CUBICLE

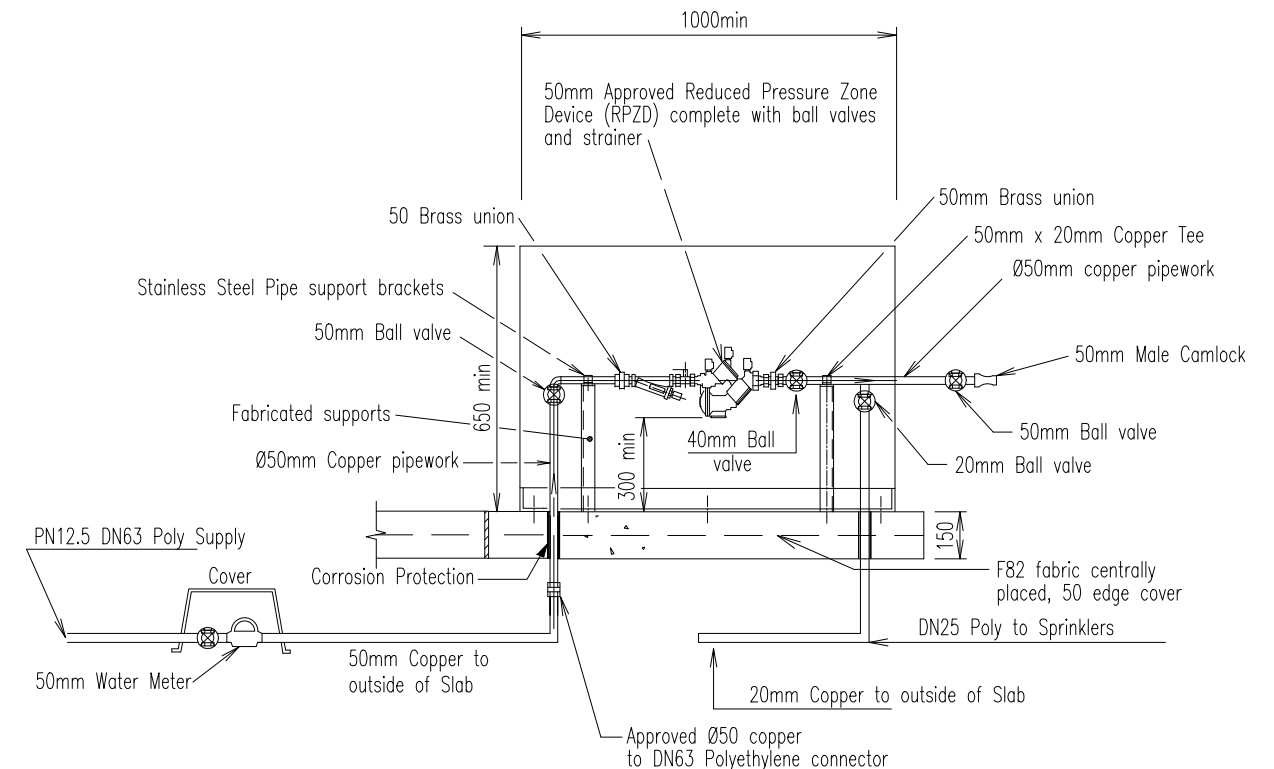

SECTION
BACKFLOW DEVICE ASSEMBLY
FOR SEWER PUMP STATIONS

NOTES:

1. This is regulated work and requires a Plumbing & Drainage Act Permit & Certificate.
2. Concrete S32 in accordance with AS 1379 Supp 1-1997/Amdt 1-2000 and AS 3600-2001/Amdt 2-2004.
3. Aluminium Sheet 5083-H321, Extruded sections 6061-T6, to AS 2848-1998.
4. All dimensions in millimetres.
5. Backflow Warning signage as per AS 3500.1

APPLICABILITY TABLE

Council	BSC	CHRC	GRC	IRC	LSC	MRC	RRC
Applicable	Yes	Yes	Yes	Yes	Yes	Yes	Yes

REVISIONS	DATE
E IRC ADDED	11/2016
D GRC ADDED	02/2014
C AMENDED 50mm BALL VALVE	22/2013
B RRC AMENDMENTS	05/2011
A ORIGINAL ISSUE	01/2010

DISCLAIMER.
The authors and sponsoring organisations shall have no liability or responsibility to the user or any other person or entity with respect to any liability, loss or damage caused or alleged to be caused, directly or indirectly, by the adoption and use of these Standard Drawings including, but not limited to, any interruption of service, loss of business or anticipatory profits, of consequential damages resulting from the use of these Standard Drawings as the equivalent of, or a substitute for, project-specific design and assessment by an appropriately qualified professional.

Capricorn Municipal Development Guidelines

Incorporating:
Banana Shire Council (BSC) Livingstone Shire Council (LSC)
Central Highlands Regional Council (CHRC) Maranoa Regional Council (MRC)
Gladstone Regional Council (GRC) Rockhampton Regional Council (RRC)
Isaac Regional Council (IRC)

**BACKFLOW PREVENTION DEVICE
SLAB AND POLE MOUNTED CUBICLE**

ROADS				
STANDARD DRAWING				
CMDG-W-030				
REV.	A	B	C	D E