

- NOTE:**
- DESIGN SAFE LIVE LOAD = 2.5kpa
 - MATERIAL GRADE:**
 A. 6mm ALUMINIUM CHECKER PLATE = 5251-P5
 B. ALUMINIUM FLAT BAR = 6082-T6
 C. ALUMINIUM ANGLE = 6082-T5
 - ALL WELDS TO AS1665

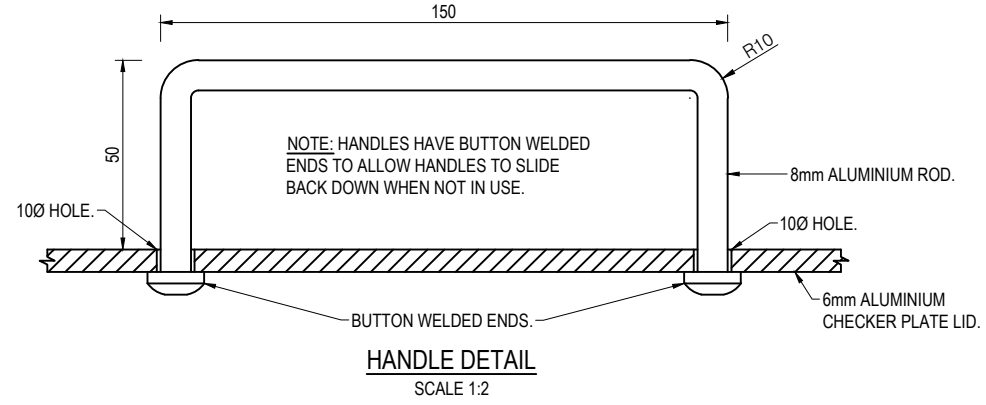
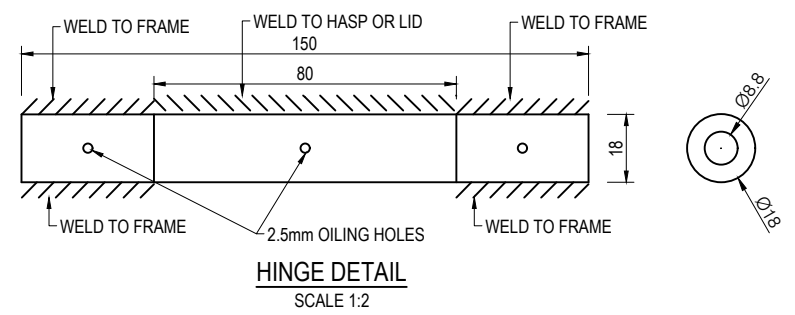
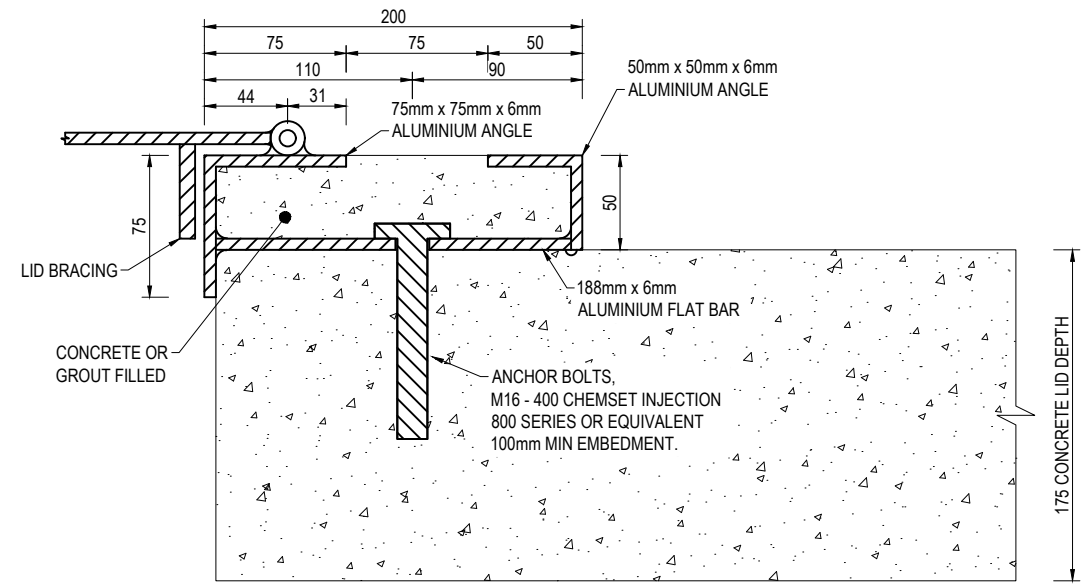
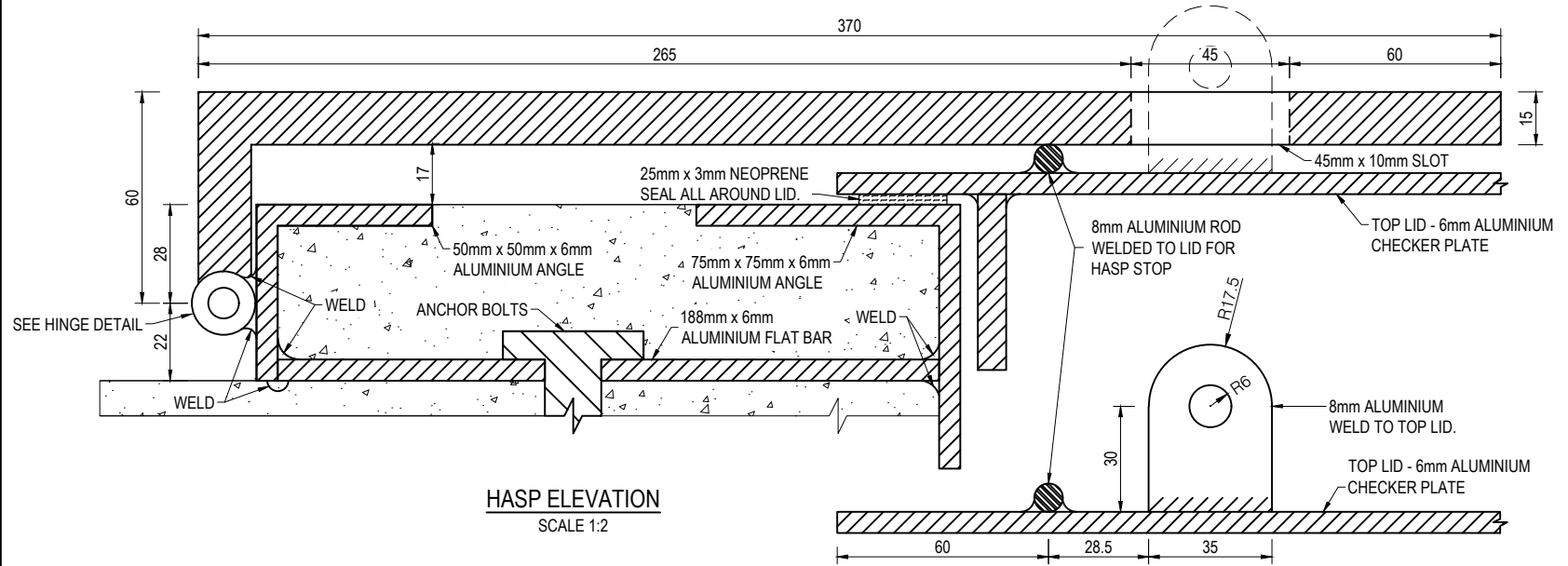
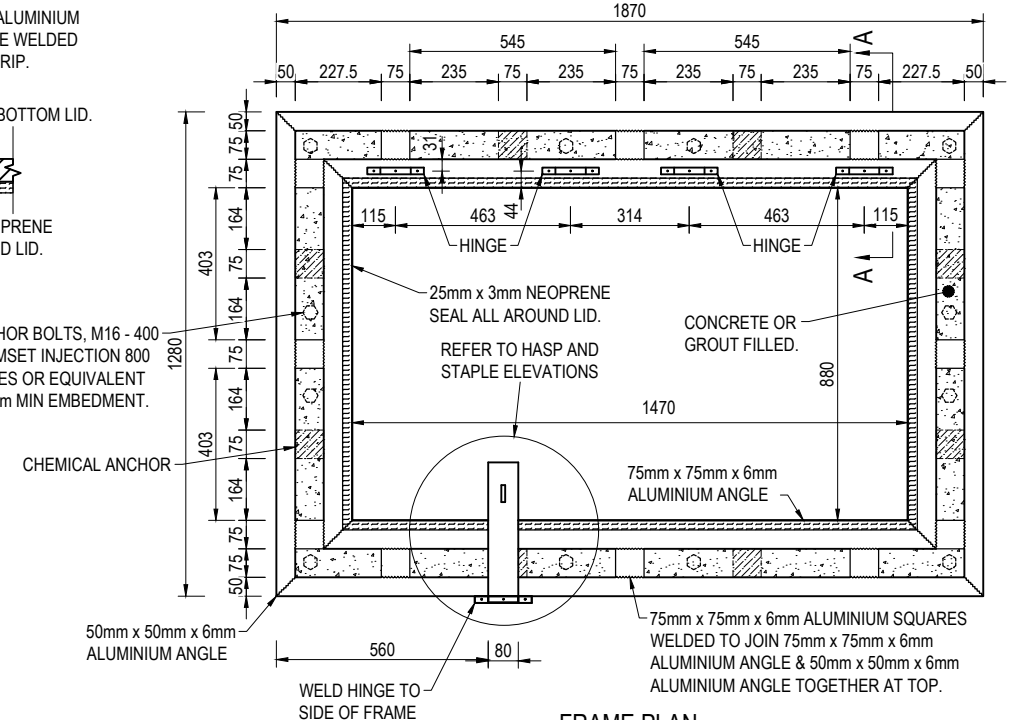
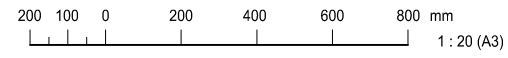

APPLICABILITY TABLE							
Council	BSC	CHRC	GRC	IRC	LSC	MRC	RRC
Applicable	Yes	Yes	Yes	Yes	Yes	Yes	Yes

REVISIONS	DATE
E SCALES & LID ARRANGEMENT AMENDED	10/2017
D IRC ADDED	11/2016
C GRC AND LSC ADDED	09/2014
B RRC AMENDMENTS	05/2011
A POST AMALGAMATION REVIEW	10/2003

DISCLAIMER.
 The authors and sponsoring organisations shall have no liability or responsibility to the user or any other person or entity with respect to any liability, loss or damage caused or alleged to be caused, directly or indirectly, by the adoption and use of these Standard Drawings including, but not limited to, any interruption of service, loss of business or anticipatory profits, of consequential damages resulting from the use of these Standard Drawings. Persons must not rely on these Standard Drawings as the equivalent of, or a substitute for, project-specific design and assessment by an appropriately qualified professional.

Capricorn Municipal Development Guidelines
 Incorporating:
 Banana Shire Council (BSC) Livingstone Shire Council (LSC)
 Central Highlands Regional Council (CHRC) Maranoa Regional Council (MRC)
 Gladstone Regional Council (GRC) Rockhampton Regional Council (RRC)
 Isaac Regional Council (IRC)

SUBMERSIBLE SEWAGE PUMPING STATION LID DETAILS

SEWERAGE	
STANDARD DRAWING	
CMDG-S-063	
REV.	A B C D E