

NOTES:

1. Model based on Department of Transport and Main Roads - Road Planning and Design Manual
2. All values used in equation for SISD can be found in the manual
3. No Landscaping Zone means no standing shrubs or trees - ground landscaping (ie) low laying gardens are subject to approval.
4. Sight distance models must be approved by Council
5. All landscaping are to be in accordance with approved species list
6. For distances regarding landscaping around power poles and street lights refer to CMDG-G-016 Street Planting
7. Subsurface drainage is required where landscaping is approved in centre median
8. Any trees planted in centre median should be set back a minimum of 600mm behind back of kerb

$$SISD = \frac{D_r \times V}{3.6} + \frac{V^2}{254 \times (d+0.01xa)}$$

SISD - Safe Intersection Sight Distance

D_r - decision time (s)

V - operating (85th percentile) speed (km/h)

d - coefficient of deceleration

a - longitudinal grade in %

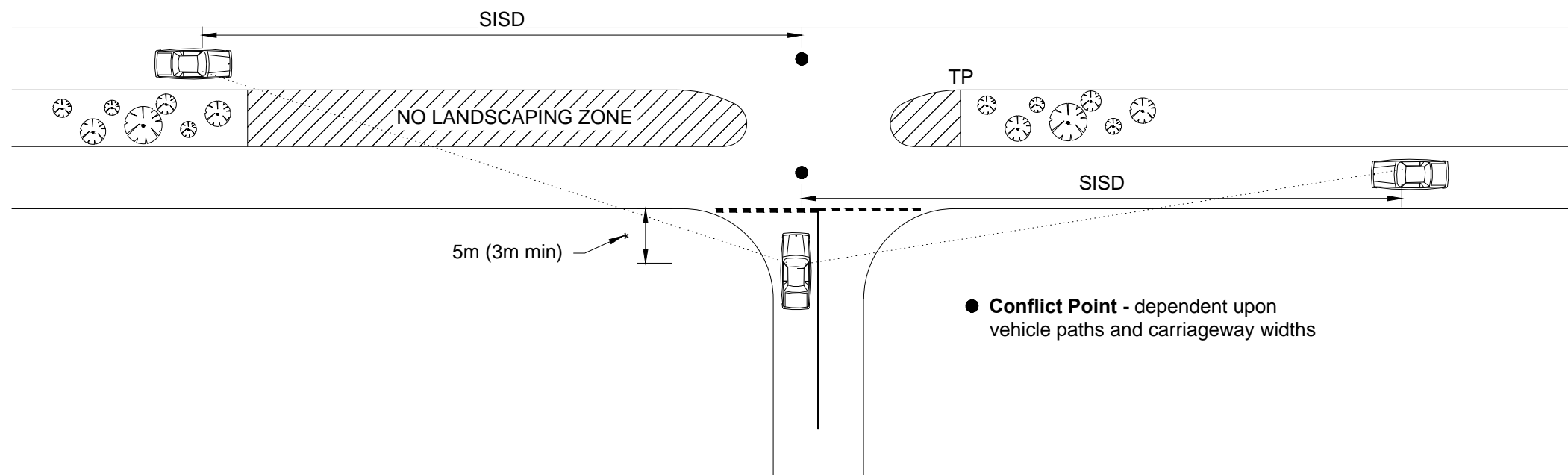

| APPLICABILITY TABLE | | | | | | | |
|---------------------|-----|------|-----|-----|-----|-----|-----|
| Council | BSC | CHRC | GRC | IRC | LSC | MRC | RRC |
| Applicable | Yes | No | Yes | Yes | Yes | Yes | Yes |
| Applicable DWG | | | | | | | |

| REVISIONS | DATE |
|----------------------------|---------|
| E IRC ADDED | 12/2016 |
| D GRC AND LSC ADDED | 09/2014 |
| C RRC APPLICABILITY YES | 07/2012 |
| B MRC ADDED | 04/2011 |
| A POST AMALGAMATION REVIEW | 06/2010 |

DISCLAIMER.
The authors and sponsoring organisations shall have no liability or responsibility to the user or any other person or entity with respect to any liability, loss or damage caused or alleged to be caused, directly or indirectly, by the adoption and use of these Standard Drawings including, but not limited to, any interruption of service, loss of business or anticipatory profits, of consequential damages resulting from the use of these Standard Drawings. Persons must not rely on these Standard Drawings as the equivalent of, or a substitute for, project-specific design and assessment by an appropriately qualified professional.

Capricorn Municipal Development Guidelines

Incorporating:
 Banana Shire Council (BSC) Livingstone Shire Council (LSC)
 Central Highlands Regional Council (CHRC) Maranoa Regional Council (MRC)
 Gladstone Regional Council (GRC) Rockhampton Regional Council (RRC)
 Isaac Regional Council (IRC)

CENTRE MEDIAN LANDSCAPING

| ROADS | |
|------------------|-------------------|
| STANDARD DRAWING | |
| CMDG-R-057 | |
| REV. | A B C D E |