

IF THIS STANDARD DRAWING CANNOT BE ACHIEVED THEN THE APPLICANT IS REQUIRED TO SUBMIT A REGISTERED PROFESSIONAL ENGINEER QUEENSLAND (RPEQ) CERTIFIED ALTERNATIVE PLAN FOR COUNCIL APPROVAL. THE DRIVEWAY DESIGN SHALL BE SUBMITTED FOR APPROVAL PRIOR TO THE ISSUE OF A PERMIT TO PROCEED WITH CONSTRUCTION.

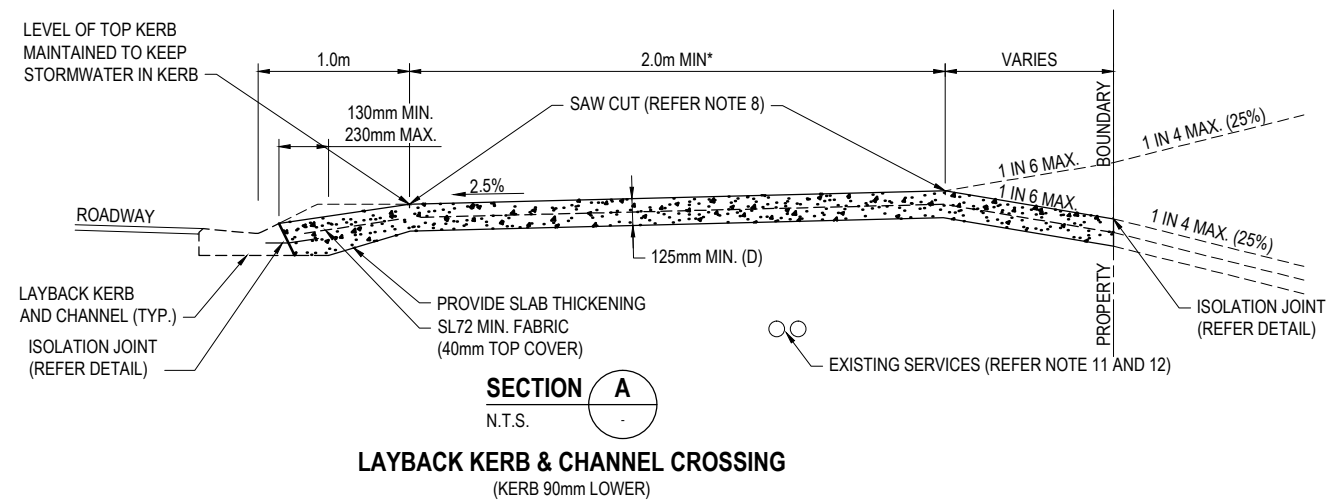
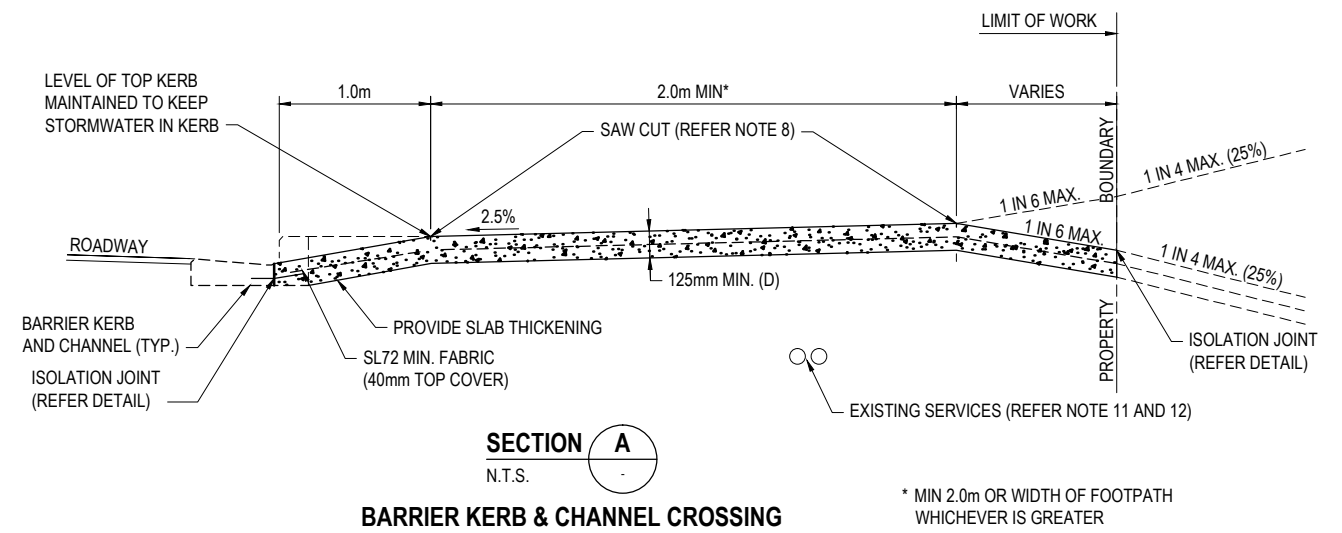

RELEVANT STANDARDS:

- AS3600, CONCRETE STRUCTURES
- AS1379, SPECIFICATIONS AND SUPPLY OF CONCRETE
- AS/NZS A4671, STEEL REINFORCING MATERIALS.

NOTES:

- CONCRETE N25 TO AS 1379, AS 3600.
- CROSSINGS ARE NOT DESIGNED FOR COMMERCIAL PROPERTIES. REFER TO COUNCIL STANDARDS FOR COMMERCIAL/INDUSTRIAL CROSSING (RT-0055.1).
- NEW FOOTPATH PROFILE TO VARY WHERE NECESSARY TO MATCH WITH EXISTING CONCRETE FOOTPATHS AND VERGE PROFILES. BASE LAYER MUST BE WELL COMPACTED AND TRANSITION SMOOTHLY TO AND FROM DRIVEWAY. ADJOINING FOOTPATH SURFACES SHALL NOT HAVE A GRADE GREATER THAN 1:8 OR 12.5%.
- NO TRACKS PERMITTED ACROSS FOOTPATH.
- CONCRETE PATH SHALL BE CONTINUOUS ACROSS DRIVEWAYS AS PEDESTRIAN AND CYCLISTS SHOULD HAVE RIGHT OF WAY.
- DRIVEWAY MAY BE USED BY THE PUBLIC TO THE PROPERTY BOUNDARY INCLUDING REFUSE OR DELIVERY VEHICLES.
- BRASS DISKS EMBEDDED IN KERB AND CHANNEL SHALL NOT BE REMOVED WITHOUT THE PERMISSION OF COUNCIL.
- SAW CUT TO BE 3-6mm WIDE x $\frac{D}{2}$, WHERE D = DEPTH OF CONCRETE. APPLY BEAD OF POLYSULPHIDE SEALANT TO BOND BREAKING TAPE
- CONCRETE DRIVEWAY SURFACE IN ROAD RESERVE SHALL HAVE A NON SLIP FINISH (BROOM FINISH).
- SURFACE TREATMENT MAY NOT BE MATCHED BY COUNCIL IF REPAIRS ARE NEEDED TO SERVICES UNDER DRIVEWAY.
- ENSURE MIN. COVER TO SERVICES IN FOOTPATH AND DRIVEWAY IS ACHIEVED TO MEET RELEVANT AUTHORITY STANDARD. A DIAL BEFORE YOU DIG (DBYD) IS TO BE UNDERTAKEN PRIOR TO COMMENCING WORK ON SITE.

- ALL WATER VALVES, HYDRANTS, SEWER MANHOLE, TELECOMMUNICATION PITS AND THE LIKE TO BE RELOCATED CLEAR OF PROPERTY ACCESS AT THE EXPENSE OF THE PROPERTY OWNER. THE RELEVANT AUTHORITY IS TO BE CONTACTED SO THAT CONFLICTING SERVICES CAN BE RELOCATED PRIOR TO CROSS OVER CONSTRUCTION
- THE PROPERTY OWNER / APPLICANT / CONTRACTOR IS TO TAKE ALL NECESSARY MEASURES TO ENSURE PEDESTRIAN SAFETY INCLUDING BUT NOT LIMITED TO BARRICADES, SAFETY LIGHTING, WARNING DEVICES OR OTHER MEANS OF PROTECTING PUBLIC RISK IN ACCORDANCE WITH THE LATEST MANUAL OF UNIFORM TRAFFIC CONTROL DEVICES (MUTCD).
- VARIATION TO THE DESIGNS SHOWN ARE SUBJECT TO APPROVAL FROM THE MANAGER ROAD SERVICES OR THIS DELEGATE.
- WHERE NEW CONCRETE WORKS ABUTS EXISTING CONCRETE WORK, 12Ø DOWELS, 300mm LENGTH (500mm LENGTH AT INVERT OF KERB AND CHANNEL) AT 300mm CENTRES TO BE INSTALLED TO PREVENT DIFFERENTIAL MOVEMENT. (REFER ISOLATION JOINT DETAIL)
- DRIVEWAY SHOULD BE LOCATED WITH A MINIMUM SIDE BOUNDARY CLEARANCE OF TWO METERS.
- MANDATORY COUNCIL INSPECTIONS ARE REQUIRED PRIOR TO CONSTRUCTION INCLUDING CONCRETE SLAB SET-UP AND REINFORCEMENT, AND FINAL INSPECTION FOLLOWING COMPLETION OF CONSTRUCTION, INCLUDING BACK FILLING TO EDGES AND ENSURING THE NEW DRIVEWAY WILL NOT CAUSE A TRIPPING HAZARD.
- COUNCIL TAKES NO RESPONSIBILITY FOR A VEHICLE SCRAPING WHEN USING A FOOTPATH CROSSOVER OR INVERT CROSSING. THE PROPERTY OWNER/APPLICANT/CONTRACTOR IS TO ENSURE ADEQUATE VEHICLE CLEARANCE IS PROVIDED.
- AN APPLICATION TO "CARRY OUT WORKS ON A COUNCIL ROAD" IS TO BE SUBMITTED BEFORE WORKS ARE UNDERTAKEN.

APPLICABILITY TABLE							
Council	BSC	CHRC	GRC	IRC	LSC	MRC	RRC
Applicable	No	No	Yes	No	No	No	No
Applicable DWG	CMDG-R-041						

REVISIONS	DATE
C IRC ADDED	12/2016
B MULTIPLE DRAWING AMENDMENTS	04/2016
A NEW DRAWING FOR GRC	11/2014

DISCLAIMER.
The authors and sponsoring organisations shall have no liability or responsibility to the user or any other person or entity with respect to any liability, loss or damage caused or alleged to be caused, directly or indirectly, by the adoption and use of these Standard Drawings including, but not limited to, any interruption of service, loss of business or anticipatory profits, of consequential damages resulting from the use of these Standard Drawings. Persons must not rely on these Standard Drawings as the equivalent of, or a substitute for, project-specific design and assessment by an appropriately qualified professional.

Capricorn Municipal Development Guidelines

Incorporating:
Banana Shire Council (BSC) Livingstone Shire Council (LSC)
Central Highlands Regional Council (CHRC) Maranoa Regional Council (MRC)
Gladstone Regional Council (GRC) Rockhampton Regional Council (RRC)
Isaac Regional Council (IRC)

URBAN RESIDENTIAL DRIVEWAY

ROADS				
STANDARD DRAWING				
CMDG-R-041A				
REV.	A	B	C	