

PLAN VIEW - 2.7m SPAN

Scale 1:100

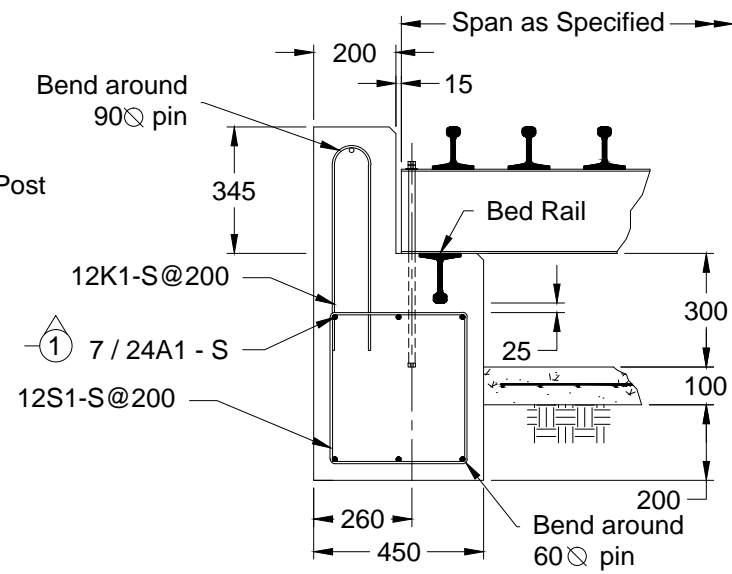

ABUTMENT DETAIL 1

Scale 1:20

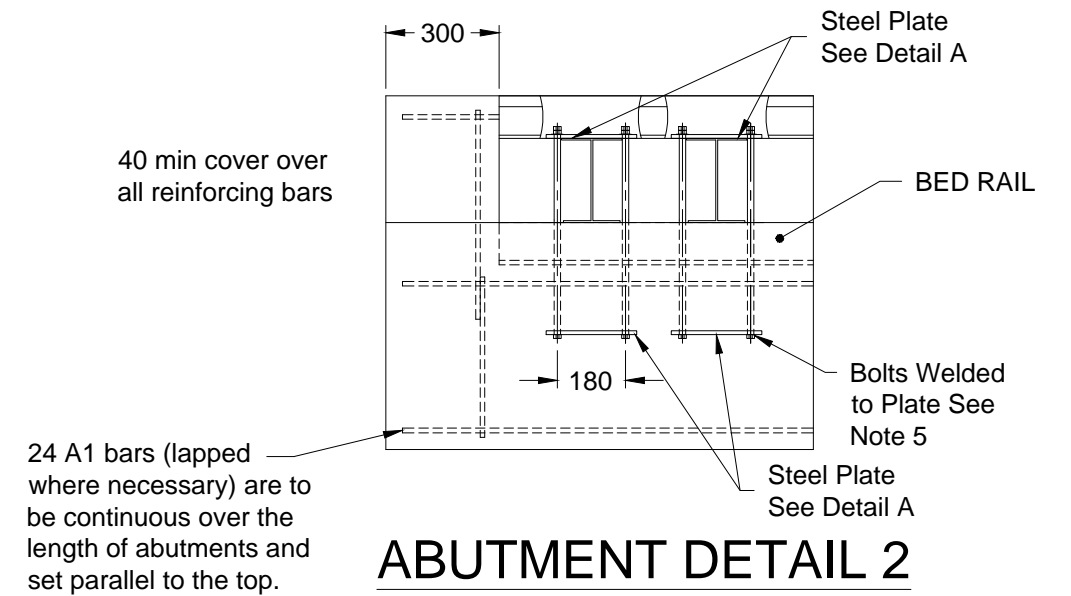

ABUTMENT DETAIL 2

Scale 1:20

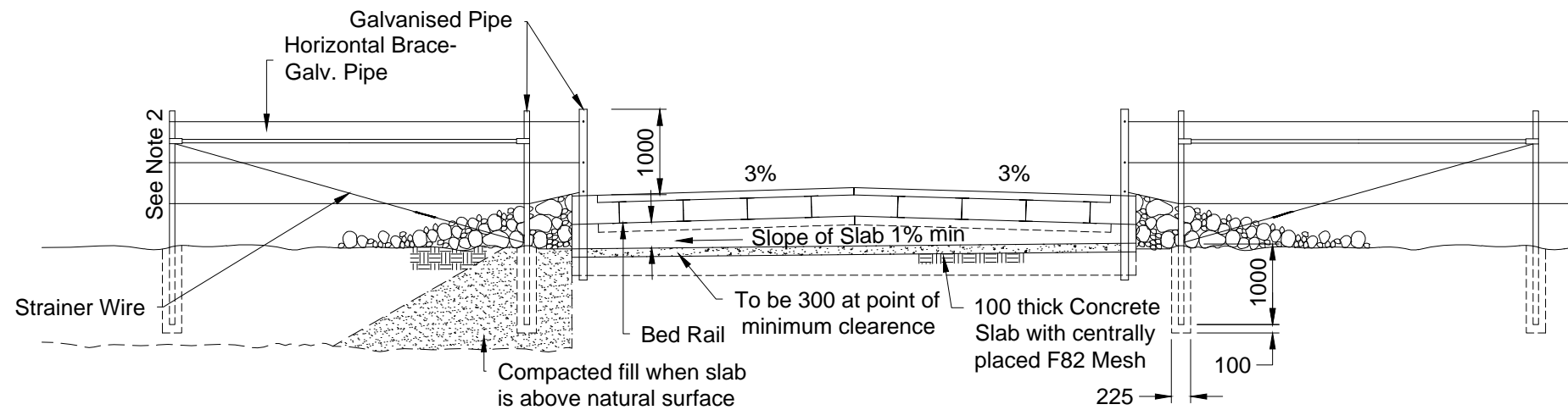

CROSS SECTION 1

Scale 1:75

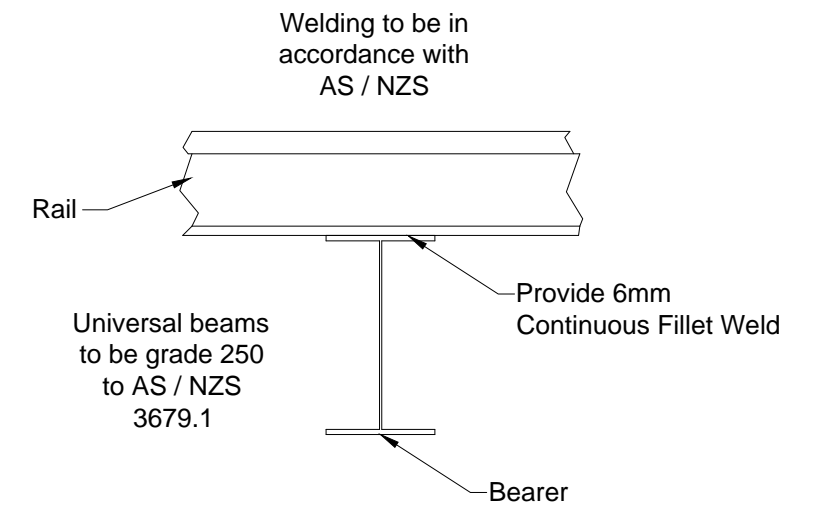

WELDING DETAIL

Scale 1:10

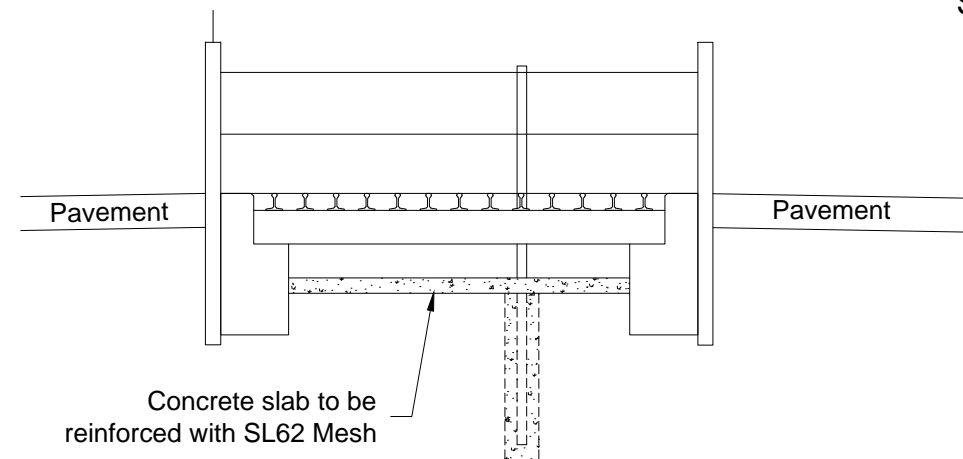

CROSS SECTION 2

Scale 1:50

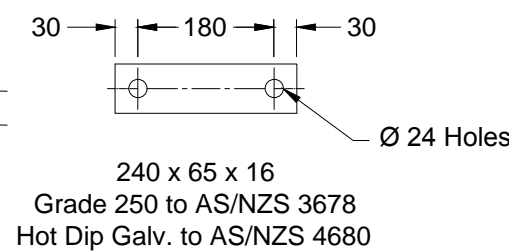

DETAIL A

Scale 1:10

NOTES:

- Grids can be either pre-cast units or cast in-situ construction. Grid rails to be made from new 22kg/m railway iron or RHS. All grids require RPEQ certification.
- Widths of Grid change depending on Road Hierarchy/ Category. For widths of grid refer to Local Council's Grid Policy
- All grids must have an accompanying gate. Refer to Standard Drawing CMDG-G-017.
- Dimensions are in millimeters unless otherwise shown
- Standard Grid Spans for 1.9 or 2.7m only
- Holding down bolts M20 x 600, Grade 4.6, 70 thread with M20 nuts & locknuts, grade 5, galv. to AS 1214 with NS washers.

*Dimensions are in Millimetres unless otherwise shown

APPLICABILITY TABLE							
Council	BSC	CHRC	GRC	IRC	LSC	MRC	RRC
Applicable	Yes	Yes	No	Yes	Yes	Yes	Yes
Applicable DWG	Refer GRC Gates and Grids Policy P-2014/6						

REVISIONS	DATE
F IRC ADDED	12/2016
E NOTE ADDED	07/2015
D GRC AND LSC ADDED	09/2014
C NOTES AND FURTHER DETAILS ADDED	07/2012
B MRC ADDED	04/2011
A POST AMALGAMATION REVIEW	07/2010

DISCLAIMER.
The authors and sponsoring organisations shall have no liability or responsibility to the user or any other person or entity with respect to any liability, loss or damage caused or alleged to be caused, directly or indirectly, by the adoption and use of these Standard Drawings including, but not limited to, any interruption of service, loss of business or anticipatory profits, of consequential damages resulting from the use of these Standard Drawings. Persons must not rely on these Standard Drawings as the equivalent of, or a substitute for, project-specific design and assessment by an appropriately qualified professional.

Capricorn Municipal Development Guidelines
Incorporating:
Banana Shire Council (BSC) Livingstone Shire Council (LSC)
Central Highlands Regional Council (CHRC) Maranoa Regional Council (MRC)
Gladstone Regional Council (GRC) Rockhampton Regional Council (RRC)
Isaac Regional Council (IRC)

STANDARD COUNCIL GRID

GENERAL
STANDARD DRAWING
CMDG-G-018
REV. A B C D E F